



**Mobile climbing wall
&
TRIPOD
Combo trampoline
Operations Manual**

REVISION 06/03/08

MIAMI, FL 33157

Tel (305) 238-4522 Fax (305) 238-4401

Web Page www.verticalreality.com

Email albert@verticalreality.com

Welcome

It is with great pleasure that we congratulate you on your combo purchase and welcome you to Vertical Reality. We are excited about our products and feel confident that through proper planning, placement and hard work, the COMBO will be a rewarding and profitable purchase. Our philosophy is centered on a commitment to excellence in meeting the needs of our customers, providing a quality product that is safe, exciting and profitable. We encourage you to likewise develop a standard of quality and service that makes you the leader in supplying artificial mobile climbing walls for the amusement, entertainment and special attractions market.

Our goal is to establish a relationship with your company. One that will promote Vertical Reality and your company, as successful partners, providing entertainment for those whom are looking for a climbing attraction.

Our part in making our team successful is:

- Commitment to proper, effective, Safe and profitable design
- Seven days per week customer service support
- Manufacturing to "ASTM F-1159-97a" ASTM F24 safety standards for the amusement industry
- Cycle time that generates high profits

Your part in building a successful business using Vertical Reality products is:

- Commitment to safe operation
- Consistent inspection for proper maintenance
- Effective marketing and promotion
- Active promotion of the activity

We are looking forward to a long and prosperous relationship. Should you have any comments or questions, please do not hesitate in calling.

Sincerely,

Ken A Sharkey
CFO

Confidentiality Agreement

This manual and the content within this manual are for the exclusive use and operation of the COMBO product by the owner of the COMBO and its authorized personnel and for Vertical Reality. This manual is designed to provide accurate and authoritative information in regard to the subject matter covered. This manual may not be reproduced in whole or part in any form or by any means, without the prior written consent of **Vertical Reality**

Confidentiality

This manual contains proprietary information belonging to Vertical Reality. It is to be viewed only by persons employed by Vertical Reality and/or the COMBO owner and authorized personnel.

Distribution

This manual is not to be distributed to any other persons other than those actively engaged in the operating and/or marketing of the COMBO product to customers serviced by the owner of the COMBO mobile climbing wall.

Disposition

This manual is the property of the COMBO owner and Vertical Reality and must be returned to Vertical Reality upon receipt of an updated manual or discarded.

Revision

Vertical Reality may make periodic additions, deletions and modifications to this manual. These updates will, in the judgment of Vertical Reality, add to the quality of services offered. This manual must be kept up to date, and should reflect all updates currently in use.

Notice of Changes

In the event that revisions are made to this manual, Vertical Reality will send the appropriate pages reflecting such changes as are deemed necessary or replacement document, to the individual for replacement. Any pages that are then outdated must be destroyed and discarded.

In the event of replacement pages are sent, Vertical Reality will provide a cover letter outlining the revision and the effective date of any procedural changes.

Receipt and Acknowledgment

This Training/Operations Manual is an important document intended to help you become acquainted with the Mobile climbing wall, Vertical Reality and guidelines as to safe and recommended operation.

Please read the following statement and sign below to indicate your receipt and acknowledgment of the Mobile climbing wall/Vertical Reality Training Manual.

I have received and read my copy of the Mobile climbing wall/Vertical Reality Training Manual. I understand that the information outlined in this manual are subject to change at the sole discretion of Vertical Reality at any time. It is further understood that the owner of the COMBO has the responsibility to ensure the correct and latest version of the manual is being used.

As an owner of the COMBO or authorized representative, it is my responsibility to

Keep this manual up-to-date with any changes that are made by Vertical Reality

I understand that my signature below indicates that I have received the Mobile climbing wall/combo Vertical Reality Training Manual and that I have read it.

Authorized Representative

Date

The signed original copy of this agreement will be held in the **Corporate Office in Miami, FL**

Receipt and Acknowledgment and Warrantee registration
PLEASE FILL IN AND MAIL TO VERTICAL REALITY
Miami, FL 33158

This Training/Operations Manual is an important document intended to help you become acquainted with the Mobile climbing wall, Vertical Reality and guidelines as to safe and recommended operation.

Please read the following statement and sign below to indicate your receipt and acknowledgment of the Mobile climbing wall/Vertical Reality Training Manual.

I have received and read my copy of the Mobile climbing wall/Vertical Reality Training Manual. I understand that the information outlined in this manual are subject to change at the sole discretion of Vertical Reality at any time. It is further understood that the owner of the COMBO has the responsibility to ensure the correct and latest version of the manual is being used.

As an owner of the COMBO or authorized representative, it is my responsibility to

Keep this manual up-to-date with any changes that are made by Vertical Reality

I understand that my signature below indicates that I have received the Mobile climbing wall/ combo Vertical Reality Training Manual and that I have read it.

Authorized Representative

Date

VIN NO
DATE PURCHASED

The signed original copy of this agreement will be held in the **Corporate Office in Miami, FL**

Training Overview

This training course is an introduction to the **COMBO** and its operation. The purpose of this manual is to provide a compilation of information that will assist you in proper and safe operation.

This manual is designed to aid in training you and your associates. The sections within this manual are prerequisite to each other. In other words, the information in section one pertains to the information in section two.

The philosophy of **Vertical Reality** is centered on a commitment to excellence in meeting the needs of its customers and associates by providing them with the enclosed information.

The manual is designed to provide the wall owner with the information, tips, and techniques that will help the employees and owner operate the wall & Combo as effectively and safely as possible. It is no way a total representation of all facts. Safe operation of this wall is the sole responsibility of the wall/combo owner/operator. Good and reasonable judgement must be used when traveling, promoting and/or operating the wall.

Training Objectives

Upon reviewing this training, you will be able to complete the following:

- Explain specific information regarding the background and history of Vertical Reality
- Understand the process for proper set-up of the Mobile climbing wall combo
- Identify and understand the inspection points for day-to-day maintenance.
- Define and understand the safe operation of the Mobile climbing wall/combo
- Identify and explain the rules for safe usage of the Mobile climbing wall/combo

Company Overview

Vertical Reality, located in Miami, FL is a manufacturer/ distributor of commercial interactive sports and fitness-fun equipment used in the amusement and recreational fitness markets. Designed for fun, VR is a premier provider of commercial action based products to be used in the amusement, fitness and recreation industry. Safely engineered VR products provide maximum revenue while providing thousands of hours of safe and exciting entertainment for your customers.

Mission Statement

To be the premier provider of revenue-generating *interactive sports* products used in the amusement and fitness markets.

Corporate Values

Our philosophy is centered on a commitment to excellence in meeting the needs of our customers, providing a quality product that is safe, exciting and profitable.

Mobile climbing wall & COMBO

Product Overview

Welcome to the mobile climbing wall, Vertical Reality's latest in revenue generating interactive sports products designed for the amusement, entertainment, and fitness industries. Complete with redundant auto-belay devices, the COMBO maximizes profit and safety. Different from other Mobile climbing walls, the COMBO does not use, what is commonly termed as, and a person for belaying. The reason for this is because of the autobelay devices. With the auto-belay devices doing all of the belay work and ensuring safety, the person(s) operating the wall act more like a coach offering encouragement and direction. The COMBO is designed to meet ASTM F-1159-97a standards for the Amusement Industry. This means that the COMBO is designed, manufactured, tested, and supported by comprehensive quality assurance and quality control measures to ensure product reliability and safety. The enclosed information is an outline as to the procedures for safe operation and set-up of the product. In addition to the climbing wall features the combo has 3 bungy trampoline stations that can be set up in conjunction with the wall to create a truly unique experience. The bungy trampoline stations utilize a powered winch to stretch elastic bands that are attached to a harness on the jumper, thereby providing a means for the jumper to achieve great heights and perform aerial maneuvers not possible on a normal trampoline.

Warranty (from date of invoice)

Product Warranty - 1 year on frame

Hydraulic Cylinder(s) - 12 months per manufacturer

Climbing Harnesses and Carabiner's - per the manufacturers warranty and specifications

Winches -90 days

What is an "Auto-Belay"?

The Belay

In order to understand the term auto-belay, we must first define the term belayer respective to traditional rock climbing. The act of belaying can be defined as a procedure of securing a climber by the use of a rope. In recreational sport climbing there are generally two people involved in a climb. A climber, the person climbing the intended surface or structure, and the person whom is providing the safety for the climber known as a belayer. The belayer's role is to use two hands on a braking device, which controls the descent of the climber. One of the functions of the belayer is to ensure the rope slack is taken up as the climber ascends and ensure that the rope does not get tangled up which would result in the climber dangling. Once the climber asks to come down, it is the function of the belayer to allow the rope to pass through the braking device such that the climber descends at a rate that is not too fast or too slow.

The biggest fears in manually lowering someone as a belayer, is that a belayer could drop the climber out of control, or let the end of the rope pass through the belay device such that the climber falls to the ground. Both of these mistakes have often happened, and to very experienced climbers

Auto-Belay

Vertical Reality is using the term "auto-belay" to describe its automated belaying process. Rather than a person acting as the belayer, Vertical Reality uses a pressurized air/oil hydraulic system that automatically controls the rate of descent when a climber falls or chooses to come down off the wall. The intended function of the automated belaying system is to take up the slack in the climbing cable as the person climbs. As a climber climbs the wall, the climber will take weight off of the cable, in which the positive air pressure in the hydraulic system causes the cable to retract or to functionally take up the cable slack. This works by air pressure forcing the hydraulic fluid into the pistons the whole sequence is reversed for the controlled decent of the climber. A human person in the sport of traditional rock climbing generally performs this function. However, the auto belay system used by Vertical Reality provides a system that automates this function. The automated system eliminates the need to rely upon a human belayer for every climber rather; allowing a single person (belayer or instructor) to supervise all three climbers. This ensures safe and proper climbing eliminating the use of a human belayer. The COMBO with its auto belay devices allows for three climbers to climb the wall simultaneously with only one person acting as a belaying coach. Whereas in traditional rock climbing, every climber would require a belayer. This simple feature means that when operating a wall for profit, the COMBO generates more profit than a wall requiring human belayer's by simply reducing the amount of labor needed to operate the wall.

Safety Standards

Is the auto belay safer than a human belayer? Vertical Reality answers this question by manufacturing their COMBO product with two hydraulic cylinders for every climber. Two cylinders mean that a redundant system is in parallel, which will ensure that if one hydraulic cylinder fails, a second system will take up the slack and function in a safe manner. In comparison to recreational climbing using manual belayer's, 2 belayer's would be required to belay for each climber. This means that there would be two belayer's for every climber. Imagine the payroll requirement you would need on a manual system to compare with the safety system featured in the COMBO Climbing Structure. However, in fairness, rock climbing has its inherent risks. A participant climbing on the COMBO can be injured. Even though the COMBO system is automated, we require that a responsible person be assigned to ensure that the mechanical function of the COMBO is operating properly. As an owner of the Mobile climbing wall, it is your responsibility to make sure constant care and supervision is taken regarding the operation of this product.

How to set-up the Mobile climbing wall

The name COMBO is the product name for the entire system (i.e. COMBO and auto belay safety system). The mobile unit has been designed to travel down the road in a down/closed fashion. Aerodynamic because of its hollow shape, the mobile unit should travel relatively easy. As a reminder, please follow any and all rules established by a state or interstate highway system that you would travel in the course of conducting your business or transport of the product. Please abide by all traffic laws and warnings.

Physical Dimensions - The COMBO meets all requirements for physical size as outlined by the Department of Transportation. The dimensions of the COMBO are:

Specifications.

4 person short trailer

- Width 88"
- Height 102"
- Length 28'
- Weight 4200 lbs

Vertical Reality 4 person wall dimensions & specifications

Physical space required once set up 7'4" X 15'

Reccomended operating space 20' X 20'

Storage space required 28' X 8' X 9'

2' ball and 7 way flat plug required for towing

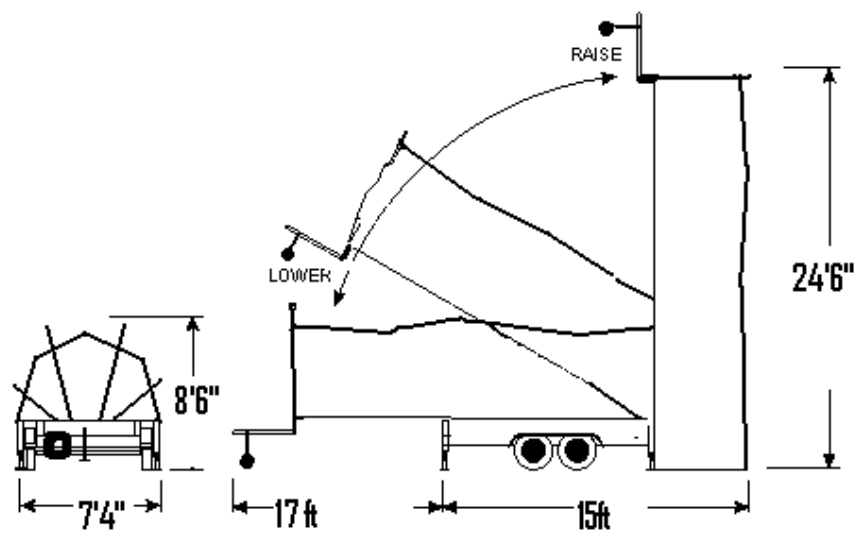

Mechanical Engineering Approval - The COMBO has been designed and reviewed by engineers that stand behind the COMBO design

Required Personnel - The COMBO must be operated by a minimum of 3 persons. However, for proper operation, Vertical Reality recommends that at least 3 or 4 people operate the attraction for optimal performance and safety. Vertical Reality recommends that one-person act as the climbing coach supervising any one or all of the climbers and a second person to harness the climber and obtain a parental consent or hold harmless signature. The climbing coach should offer encouragement, entertain the climber and most importantly watch the belay cable to ensure that there is no excess slack in the cable or that the climber does not out climb the auto-belay device. The second person in charge of harnessing should ensure the Harness is worn correctly. A third person should operate the 2 trampoline units and harness, pay close attention too the jumpers.

Hitch and Wiring - To pull the COMBO you will need a 2-inch ball and a seven- (7) prong FLAT BLADE wiring plug. Remember that your tow hitch must be equipped with a 12-Volt charge if you want the battery to charge as you are towing the unit. The new design of the trailer eliminates the use of electric brakes as surge brakes have been fitted to the trailer. For the folding trailer we use electric brakes and hydraulic brakes as an option. Please also ensure that you have an electric brake controller installed for the brake to work.

Setting up the COMBO wall with the short trailer design- the bungy section is set up separately

1. Upon parking the COMBO trailer in place, remove the trailer from the towing vehicle. Disconnect all wiring and chains from vehicles.
2. Level the trailer using the single rear jack such that the trailer dolly wheel is off the ground **FOLD UP THE DOLLY WHEEL**
3. Unlatch the rear jack arms and extend them as the diagram shows

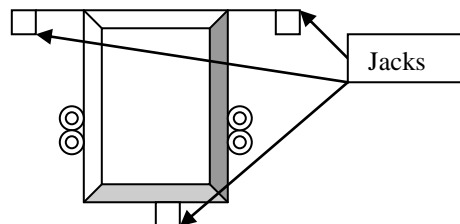

4. Jack up the jack arms so the tires are at least (1) inch off of the ground. **Make sure that the jack pull pins are properly inserted before engaging the jacks** (If Additional Height is required you may use a wood block under the jack plate).
5. Remove the retaining travel pin from the trailer
6. Attach a rope to each of the auto belay cables.
7. Locate the hydraulic lift control switch located on the driver's side of the trailer at the rear on the top piece. **Make sure there is proper clearance for the arc of the wall before up-righting the wall.** IF YOU HAVE THE FOLD UP TOUNG DESIGN THEN

YOU CAN REMOVE THE PULL PIN AND THEREBY ENABLE YOU TO FIT INTO A 25 FT CEILING HEIGHT IF REQUIRED

8. **DO NOT PUSH AND RELEASE THE CONTROL BUTTON MULTIPLE TIMES WHILE RAISING THE WALL.** Rather, hold the button in continuously until the wall is upright. Once the wall is up using the leveling jacks, lower the trailer so that the COMBO frame is resting on the ground in whole or in part, maintaining level on the trailer frame. Make sure that only the metal frame is resting on the ground. If an obstacle or high point is the fiberglass before the metal frame is resting on the ground, you will break the fiberglass. As an option, if only a portion of the metal wall frame is resting on the ground, shim up the portion of the wall base not touching the ground with wood or metal shims. Shim only the metal frame!
9. At this point, the wall should be in an upright and locked position, the trailer level and at least a portion if not the entire wall solid on the ground (using shims if not).
10. Pull each cable down 1 at a time 6 inches and check for proper retraction.
11. Check to see that the oil pressure is 40 lbs WITH ALL THE CABLES AT THE TOP.
12. Check to see that there is at least 4 inches of oil in the reservoir.
13. Pull the auto belay cables from the top of the wall by the ropes and secure to the climbing anchors on the bottom of the wall.
14. Check that the auto belays are functioning properly and pull them up and down a few times so the hydraulic oil will fill up the cylinders (bleed the system).
15. **Absolutely no climbing should be performed on the wall if the auto-belay is not functioning.** Make sure to always inspect the Auto-Belay devices to ensure proper air-tank pressure (40 lbs with the cables at the top), hydraulic leaks, pulley condition, the belay cable is taking up slack, etc.
16. DO NOT operate the wall if wind speeds exceed 30 mph. It is the responsibility of the operator, climbing coach, owner, or other responsible party to be aware of weather conditions and make the appropriate call for closure of the wall if necessary. When closure of the wall is necessary, put the wall in the down position.

Set up of the combo section

1. Attach the poles to the swivel bases by using the 5/8 pins.
2. Attach the cables to each of the eye-nuts at the top end of the poles with the supplied carabiner.
3. Attach the other end of the cable (turnbuckle end) to the adjacent pole eye nut 6" from the Swivel base with another carabiner.
4. Attach a jump set to each eye-nut (see diagram 2).
5. Pull out the post supports (or swing out depending on the model that you have) and pin them in place and attach the jacks to the support post.
6. Attach the motors to the frame and let out about 20 feet of winch line.
7. Attach the winch line to the winch pulley on the center of the jump rope
8. Now with the aid of 1 person lift any one of the poles onto its cradle and secure it with a Pin.
9. Do the same with the other 3 poles and then tighten all the cables.

10. You are now ready to operate.

Takedown of the wall - Upon the end of an event or use of the wall, please follow the following steps to ensure safe and proper takedown of the Mobile climbing wall.

1. Let the auto belay cables go up to the top of the wall with the supplied ropes.
2. Set the bungy poles down and pack all bungy equipment away.
3. Raise the COMBO off the ground 2 - inches using the trailer jacks.
4. After ensuring that it is safe to lower the wall and that there is proper arc clearance, press the switch in the down position and hold firmly until the wall middle support touches the trailer frame
5. Secure back-up chains and emergency brake cable.
6. Connect wiring for lights.
7. As always, make sure to obey all traffic laws and regulations.

Inspections and Preventive Maintenance

Daily Inspections

As a means of properly maintaining the COMBO and ensuring proper safety for the climber and Jumpers daily inspection is required. Cables connection points and ropes must be inspected daily. **Cables must be inspected daily. If fraying or rusting has occurred, replace the cable immediately. Inspect the cable ends by the crimps. If fraying or Rusting broken strands, replace immediately. If the cables are kinked or show signs of wear, replace them as a matter of precaution, the cables must be replaced annually.** With one operator on the front of the wall, manually extend the cable to arm's length while a second person inspects the retraction of the cable to ensure there is NO SLACK behind the wall. In addition, check each and every harness to ensure the stitching is tight and that the harness is in good working order. If the harnesses are visibly worn or are not functioning as intended discard immediately and replace with new harness. Again, as a matter of precaution, you may want to replace harnesses yearly. For proper function of the auto belay system, make sure that the air pressure is between 35 lbs. and 40 lbs with the cables at the top of the wall. Inspect daily for oil leaks, should a leak occur call Vertical Reality for details. The appropriate amount of hydraulic fluid is 6 quarts and should be AW 32 hydraulic oil. For reference, the fluid level should be approximately. Minimum 3 inches from the bottom of the tank when the all the cables are at the top of the wall. If any questions, please call Vertical Reality. If equipped make sure to check the function of the swivels on each cable end. Make sure the swivels turn freely and are in good condition. **Check Carabineer's to ensure they function properly. If they stick open or do not lock positively, replace immediately. Check Carabineers for excessive wear, if worn replace immediately.** Lastly, make sure the handholds on the wall are tight. If any of the handholds spin or are loose, tighten them. With all parts supplied from other manufacturers besides Vertical Reality (i.e. harnesses, Carabiner's, swivels) make sure to read and understand their respective warnings and instructions.

Weekly Inspections

Inspect pulleys once a week. The auto belay pulleys are at eye level and can be inspected from the ground. For stationary walls, the guide pulleys at the top of the wall must be inspected by climbing up the front of the wall and inspecting from the front. Tie one end of the belay rope to the Carabiner's end of the belay cable. Release the cable, while controlling the ascent with the rope, and let the cable travel to the top of the wall. Make sure there is a smooth ascent and while pulling on the rope, a smooth descent (retraction of cable). The purpose of this exercise is to ensure that the mechanical function of the auto-belay is operating properly. If you experience any slack, call Vertical Reality for advice and instructions.

Mobile walls can be let down and inspected from the ground. For mobile units, inspect all hydraulic hoses after each travel trip. Check tire pressures on mobile units making sure they are at proper pressure. Check to make sure the hydraulic fluid is at an appropriate level. Always make sure that the fiberglass panels are not damaged in transit or if worn out, call to replace panel(s). Inspect all ropes, carabineers and connection points. Ensure the proper operation of the winch system.

Annual Inspections

Trailer Frame and pulley bar assembly to be checked for proper attachment and weld condition inspected annually by visual inspection...Please note some states require an additional magnetic particle inspection, please check with local laws****

Wear Dated Items

The following items are wear-dated items along with suggested guidelines for replacement:

- *Carabiner's* - It is well known that equipment deteriorates progressively with use. It is difficult to give a precise lifetime because it depends on the environment where it is being used. Surface damage, corrosive wear, mechanical wear, or impairment of the mechanical function of the product is easily observed.
- *Swivels* - Again, the same warning for the Carabiner's apply to the swivels.

Pulleys - Replace when worn

Cables - Cables -annually (every12 months regardless of condition) or 10000 cycles if equipped with a counter or sooner if frayed / rusted or kinked or crimps show signs of deterioration. Cables must be purchased pre-assembled from Vertical Reality or installed by an approved Vertical Reality MFG representative.

Ropes- As needed if worn or frayed

Handholds - As needed. Handholds wear out on a regular basis, call Vertical Reality for replacements.

Harnesses - Replace when the fabric has visible cuts, tears, abrasion and/or damage caused by use, heat chemicals etc. The stitching is cut, tom worn or loose threads. Or, when the buckles are not functioning properly

Day-to-Day Operations

Now that the COMBO is set-up and ready for operation, you've performed the appropriate inspections, its time to address the issues of proper climbing. And Jumping

Equipment - All three climbing runs are set up with auto locking Carabiner's. We strongly recommend auto-locking Carabineer's because of the safety feature of the auto-locking mechanism as well as the AMP or omega auto locking carabineers that have a minimum rating of 23 KN. In addition, we strongly recommend the Vertical Reality climbing harness. This particular harness does not require a double-over requirement for securing the strap that other climbing harnesses require. Not only is the Club a safer harness, it is a harness that participants can secure with little help from the climbing coach because the harness is more straightforward and simpler to fasten Any of these products can be ordered from Vertical Reality for approximately the same cost, as any local climbing retail store would offer.

For maximum through-put, we recommend that a second person (harness assistant) other than the climbing/belay coach make sure the climbing harnesses are tight and secure and are being worn properly. Having several climbers harnessed and ready to go ahead of time will result in maximum utilization of the wall.

Belay Coach & Harness Assistant- The belay/climbing coach is responsible for proper climbing. I- Es/her role is to ensure that the participant understands the rules and double checks the harness and equipment to check for appropriate wear and function. The belay coach is responsible to make sure that there is NO CABLE SLACK in the climbing line. In addition, the belay coach should be the ONLY non-climbing person in the 6' rappelling area in front of the wall. At Vertical Reality, we refer to this area as the "Climbing Zone" and its purpose is to provide a safe area whereby a climber can rappel without fear of coming down onto another person. The belay coach has the responsibility to ensure that each climber is safely directed out of the climbing zone, back to the harness area for removal of the harness after his or her completed or attempted climb. The belay coach should

Offer positive words of encouragement to both climbers and spectators. The more fun the belay coach can make the experience for the climber, the more enjoyable the event will be for the participant. Happy customers result in repeat business. The belay coach will be asked questions from the crowd and should try to answer questions without taking their eyes off of the climber. In an effort to assist the belay coach, the harness assistant should try to address all questions, if possible. This will allow the belay/climbing coach can manage the climbers on the wall effectively.

Harness assistant - This person's responsibility is to make sure the harness is being worn correctly for climbing. This person should make sure the appropriate harness is worn correctly (i.e. small children in a children's harness, a small to large person in the adult large harness, and a large adult in the adult extra large harness). In addition, the harness assistant should recite the rules to the climber such that after the belay coach reviews the rules, each climber will have heard the rules twice. The harness assistant should try to take an active role in answering all questions from the crowd so that the belay coach's attention is with the climbers. The harness assistant should always watch the wall in an effort to assist the climbing/belay coach in proper climbing.

Rules and Safety Tips - First, insure the climbing coach has double-checked the wearing of the harness and has properly instructed the climber on the climbing rules; which are:

1. Climbers stay within the respective climbing route, generally marked with different color handholds. If matching handholds, the four-foot area directly under the belay cable outlines the climbing area.
2. No swinging from side to side.
3. No stepping on the belay cable.
4. No climbing if cable does not retract.
5. Communications with the climbing coach only, no distracting other climbers with idle conversation.
6. When rappelling, keep the kick-off distance to a minimum (approximately. 2 - 3 feet from the wall).
7. No climbing with shoes without toes or toe protection (i.e. no sandals, thongs, etc.).
8. DO NOT allow a climber to climb beyond the wall top. A climber should never climb higher than chest high to the top of the wall.
9. The weight range for the wall is 40 - 250lbs. It is possible for a child weighing less than 40 lbs. to climb the wall as long as the climbing harness is properly fitted. However, the climbing rope provided with the unit may need to be attached to the child's harness and the child pulled down after the climb.
10. Do not allow someone to sit and bounce on the belay cable when finished rappelling. Have them rappel onto their feet.

As a note, it may be necessary for the climbing coach to climb the wall to retrieve a child who may be frozen in place afraid to come down after they have climbed to whatever height.

By way of recommendation, as the climber climbs the wall, the belay coach should be interactive by offering positive words of encouragement and possible hand or foothold selection. As a climber rappels after having climbed to the top, make sure the area on the ground is free of any individual who could possibly get in the way of the repelling climber. The distance we recommend approximately. Eight (8) feet from the front surface of the mobile climbing wall. The only person who should be in this eight-foot area is the climbing coach. Upon the completion of a climb, the climber must wait for direction from the climbing coach before proceeding to the harness area for removal of the climbing harness. Likewise, the upcoming climber must be advised by either the climbing coach or the second person ensuring proper fitting of the harness before proceeding to climb on the wall. This will ensure that a rappelling climber will not descend onto an upcoming climber. *As an additional note, although Climbing Helmets are not required, we strongly recommend their use.*

JUMPING

Operational & Safety Guidelines

The Operational & Safety Guidelines Must Be Carefully Read and Followed Before Using the COMBO Power Jump

C. The Winch

The winch, which runs on 110 or 220Volts depending on which version was chosen at time of delivery. is the mechanism that allows for the raising and lowering of the jumper. It is very important that the winch is not placed in or around standing water. Do not use the winch if it is raining. Should the winch get wet, be sure that it is completely dry before operating it again. When the winch is in use, double check that all ropes are untangled and moving freely; this should be monitored constantly. Make sure

that the winch and all ropes attached to it are in good working order. **Never pull up with the winch when the knot on the rope is closer than 2 inches to the pulley on the top pole** .Stop the lowering motion of the winch before the rope is loose. The instructor should use the winch to help the jumper achieve the highest possible jump. Pull up the winch while the jumper is in the upward motion. Do this with extreme care and caution. Ideally, the jumper should never go deeper than 4 to 6 inches into the air trampoline. Always monitor the cable or rope of the winch for tautness and that it is entering the winch from the bottom. Finally, do not allow any non-staff person to operate the winch controls or be near the winches at any time.

D. The Elastics

The elastics are the fundamental element of the COMBO, in a combination of both single and double elastics. The elastics, in conjunction with the harness, connect the jumper to the frame of the COMBO Power Jump and it is the elastics system that allows the jumper to reach such incredible heights while simultaneously providing the stability for acrobatic movement. The elastic loops are 6 feet long. This dual system allows for the various weight ranges of the jumpers, which must be between 40 and 220 pounds. The elastics should be monitored constantly for signs of wear and tear. Should elastic break or look worn, replace immediately. The elastics have a life span of approximately 3500 jumps (based on 5-minute duration) or about 300 hours of operation. The elastics should be replaced regularly for optimal use and safety. Only replace Vertical Reality elastics with Vertical Reality elastics; do not use any other elastic system in the COMBO. **Failure to do so will void your warranty and create an unsafe situation.** Be sure to store the elastics in a cool dry place. Sprinkle Baby powder or Climbing Chalk On the elastics periodically to keep them in good condition. Should the elastics get wet, dry them completely before using them again. . If you have any questions or concerns about the installation of the elastics, contact Vertical Reality- for service. Make sure that all Carabineer's (snap-links) are in closed position and tightly secured before each use. Never use less than 2 elastics per side of the harness. Do not allow the elastics become entangled.

E. The Weight Range Table

* The minimum weight of a person using the COMBO Power Jump should be no less than 20 pounds.

* The maximum weight of a person using the COMBO Power Jump should be no more than 220 pounds.

The following table shows how many elastic Loops should be utilized per side Of the harness with these various weights:

Weight POUNDS	Blue / Black Loops	Amber Loops	Yellow Power Cords	Black Power Cords
40 – 45		2		2
46 – 60		3	1	1
61 – 79	1	1	2	
80 – 99	2	0	2	1
100 – 120	2	1	3	
121 – 145	3	0	3	1
146 – 165	3	1	4	1
166 – 190	4	0	5	
191 – 210	4	1	5	1
211 – 220	5	0	5	2

* Use the higher number of elastics if jumper is on upper end of weight range and/or if jumper is very dynamic and athletic.

- Never use any elastic that show signs of wear and tear.
- Never use less than 2 elastic loops or powercords per side

* Always **replace elastics with Vertical Reality elastics; failure to do so will void your warranty.**

F. The Harnesses

The harness is the actual link between the jumper and the COMBO, as it straps the jumper to the elastics system. To safely utilize the COMBO, both the jumper and the instructor need to fully understand proper

Harness fitting, adjusting, and positioning techniques. There are 3 sizes of harnesses: Small (S), Medium (M), and Large (L). The jumper should be fitted in a tight-fitting harness; the jumper should wear the smallest size he/she fits. Getting a proper size is very important for both safety and comfort. There is also now a one size fits all harness that is acceptable for use. **SHOULD THE CIRCUMFERENCE OF THE JUMPER'S HIPS BE TOO SMALL TO ALLOW THE COMPLETE TIGHTENING OF THE HARNESS WAIST-STRAP IN A SECURE MANNER, DO NOT USE THE COMBO. FAILURE TO MAINTAIN A SECURE WAIST WITHIN THE HARNESS WILL RESULT IN AN UNSAFE CONDITION.**

The following is proper harness fitting procedure:

- The jumper is to stand in front of the harness.
- Place the top strap above the hips of the jumper.
- Close the buckle by putting one end into the other end of the buckle (like in a car seat); make sure the mechanism "lock".
- Tighten the strap around the hip, don't tighten too much, and check the jumper feels comfortable.
- The carabineer (safe snap links) should be on the outside and above the hips of the jumper.
- If you cannot close the strap completely, use a smaller harness.
- Put the leg straps around the legs.
- Close the buckle and make sure it's locked.
- Tighten the strap around the leg and check the jumpers' comfort!!! If the jumper does not fit in any of the harnesses, do not use COMBO!!!

The harness should fit the jumper tightly, but not so tightly that it is uncomfortable. The harness straps should rest comfortably at the top of the thighs and around the buttocks. Make sure that the clothing of the jumper is not bunched or gathered beneath the straps. The instructor should ask the jumper how the harness feels and make sure that the jumper is comfortable and confident in the harness. The jumper should be told to voice any concerns with the harness and or his/her comfort at anytime during time on the COMBO. Should the harness become uncomfortable for the jumper during their time, instruct the jumper to stop their movement and lower the winch down so the instructor can fix the harness?

G. The Frame

The aluminum poles and innovative design is what makes the COMBO unique. With this incredible layout, 3 jumpers can experience the fun at the same time. Make sure that the frame is clean and dry while operating the COMBO. Well maintained equipment lasts longer and gives a great impression. Be sure to secure all cables and bolts properly, see the construction manual for instructions. All binding units and connection points should be completely closed and secure and should be monitored throughout usage. All ropes connected to the frame should be straight and able to move freely through the pulleys. Stop the operation immediately if any of the above is malfunctioning!

H. The Suspensions (trampolines)

The suspensions are the elements of the COMBO Power Jump that allow the jumper to rebound and gain momentum by providing a bouncy cushion. Once the jumper is standing safe on the trampoline, attach the harness immediately like described above and then pull the winch up slightly at first to

ensure the jumper does not fall off the trampoline. Make sure that the jumper is always connected to tightened elastics while on the trampoline. The instructor should not allow any horseplay on the trampolines. Be sure to completely deflate, fold, and store air trampolines in a dry place. Wipe air trampolines down with a cloth periodically. The suspension system is half of the fun in using the COMBO Power Jump but the jumper needs to be very careful on it as well. This means that the instructor needs to always be aware of the jumper and his/her placement on the trampoline. The jumper should try to stay in the center of the trampoline for maximum stability and height. The instructor should not allow anyone else besides the jumper on the trampoline while the COMBO Power Jump is in use.

Safety

A. Safe Usage & Warnings

It is very important that before using the COMBO Power Jump that the system has been properly installed according to the construction manual. If you have any questions concerning the COMBO Power Jump construction, suspension system, elastics system, or frame, contact Vertical Reality. Be sure that the proper amount of space is given for the construction of the COMBO Power Jump-- 22 feet X 32 feet X 24 feet (height) minimum. It is best to allow an additional 6 feet of height for extra safety coverage. In addition, be sure to erect the COMBO Power Jump on a relatively flat ground. Flat, grassy fields or asphalt are ideal for the COMBO. Do not erect the COMBO Power Jump on a hill or a bumpy surface that cannot resist weight or pressure.

Never allow horseplay around the COMBO. Although this is a fun activity that everyone can enjoy, it must be managed and participated in safely. Do not allow any non-staff person to be near the winches or cables. The on-site manager must maintain a safe environment not only for the jumpers but also for the instructors. Keep lines around the COMBO Power Jump orderly to prevent confusion. No smoking, food, or beverages should be allowed in the COMBO Power Jump area.

The instructor must always monitor the height of the jumper's bounce, making sure there is always enough clearance. Also, be sure to monitor the jumper's position on the trampoline and their approximation to the beams of the COMBO. Do not let the jumper bounce too far away from the center. Always maintain a minimum of 3 feet of clearance for the jumper. Use the winch to maintain this position.

THIS IS A HIGH ACTIVE SPORT! Persons who have bad backs, necks, shoulders, broken bones, heart or lung problems, pregnancy, or any other medical condition should not participate in this activity. Jumpers should be in good health and should not be under the influence of drugs or alcohol while on the COMBO. Jumpers should read and obey all rules, warnings, and instructions and should know they participate at THEIR OWN RISK. Vertical Reality cannot be held responsible for any injuries incurred and/or items lost broken while on the COMBO.

B. Daily Check List

The following activities should be performed before the COMBO Power Jump is used:

- Check all cables and cable attachments for tautness and stability.
- Check all Carabineer's (snap-links) for unusual wear. Be sure they open and close properly.
- Check the winch for proper movement and that all cables can move freely.
- Check to see that the ropes are moving freely through the pulleys and are not frayed.
- Check all elastics for wear and tear--replace if necessary.
- Check all connection points of the frame.

- Check to see that all bolts and pins are in place and secure.
- Check to see that all Swivels and Quick links are not worn and are tightly fastened.
- Check all connection points of the harnesses. Replace if showing signs of wear
- Check air trampolines for proper inflation.
- Check steel frame trampolines for security and be sure soft protectors cover springs.
- Check that all signs and warnings are properly posted.

III. The Staff

A. The Interaction between the Instructor & Jumper

The instructor plays an integral role in the success of the jumper while on the COMBO. He/She has a tremendous responsibility to maintain the jumper's safety at all times, while giving support and advice to aide in the jumper's movements. This involves listening and communicating with the jumper at all times and being aware of their situation. The instructor must constantly monitor the winch for optimal jumps while keeping the jumper from landing on the trampoline in an incorrect fashion. The instructor needs to relate helpful hints and always encourage the jumper's success.

B. The Professional Instructor

The skills of a professional instructor include more than the ability to properly connect the jumper to the COMBO. The COMBO Power Jump has the potential for 4 instructors that must not be aware of their own station, but they must also work as a team for the safety of everyone involved. The professional instructor needs to be completely aware of the jumper's situation, maintaining the highest level of safety possible. In addition, the instructor needs to fully understand the construction design, the elastic, and harness systems. The instructor should experience the COMBO Power Jump for himself or herself and should understand how to facilitate bodily movements. The instructor must be a good motivator and must always listen to the jumper's concerns and impulses. The instructor must be a good communicator with a positive attitude and helpful words.

C. The On-Site Manager

It is the responsibility of the on-site manager to maintain the safety not only of the jumpers but also the four instructors operating the COMBO. It is very important that the on-site manager inspects the equipment daily and monitors all activity. The on-site manager needs to keep the area around the COMBO Power Jump orderly by creating lines and keeping the peace. He/She also needs to always to watching for small children that might wander in dangerous areas. The on-site manager has the final word on any discrepancies concerning jumpers and/or problems. The on-site manager needs to make sure that his/her instructors are following proper procedures and are not intoxicated or falling asleep on the job. These things could compromise the safety of others and should be monitored at all times.

IV. The Jumper

A. Helpful Hints

Practically anyone can participate in the COMBO Power Jump and enjoy Spectacular movement and exhilarating fun. The jumper must be no younger than 18 month of age and no more than 99 years of age (if in good health) and must weigh between 20 and 220 pounds. Although the jumper need not be Athletically inclined, it is important that the jumper be in good health. It is also very important that the jumper obeys all posted rules and warnings and listen to the instructions given. The jumper also needs to communicate with his/her instructor concerning their comfort and movements. Most importantly, the jumper needs to be honest with his/her weight for proper harness fitting.

Here are some hints to ensure success:

- The jumper should hold onto the elastics at all times, using them for support and stability.
- While holding onto the elastics, the jumper should pull on the elastics, using their muscles to increase their height and momentum.
- The jumpers need to feel and go with the bouncing motion, using the trampoline to boost themselves higher.
- The jumper should use the upward motion and momentum to accomplish summersaults/flips. These can be best accomplished if attempted at the maximum height of the bounce with the jumper's legs tucked into the body and head tilted in the direction of the desired summersault.

B. Precautions

As stated earlier, the COMBO Power Jump is a high action sport. Jumpers should be in good health. Someone should not participate if they have neck, back, or shoulder problems, broken bones, pregnancy, heart or lung conditions, or any other medical condition that could cause further injury. Jumpers should not be intoxicated while using the COMBO Power Jump and should respect the equipment and the staff at all times. Failure to comply with these rules will result in the forfeiture of the jumper's participation. Vertical Reality. Cannot be held responsible for lost or damaged items while on the COMBO; JUMPERS PARTICIPATE AT THEIR OWN RISK.

Entertainment Tips - Never forget that your

COMBO is a fun attraction and will draw attention. Use this unique feature to book company picnics, birthday parties, corporate promotion events, special events, public attractions, fairs and festivals to name a few. Never forget that the wall can be equipped for corporate advertising generating revenue up and above the charge by the climb revenue. The belay coach should be someone who enjoys people and has a positive rapport with people making your attraction fun for the entire family. Remember that this wall was not necessarily designed for climbers. Route the wall for the intended market - those who have always wanted to give rock climbing a try. The COMBO is a product designed for fun!

Marketing ideas to Consider

This information is in no way comprehensive. It is a dynamic list that keeps growing. However, for the purpose of brainstorming and generating ideas, the following are marketing considerations.

- Corporate Sponsorship
- Sports Event Marketing
- Fairs
- Parties
- Charity Events
- Graduation Parties
- Tourist Attractions
- Trade Shows
- School Events
- Amusement Park Lease
- Street Festivals
- Radio and Television Station promotion
- Etc.

Make sure to work with your local Chamber of Commerce, Convention Bureaus, Non-profit Organizations and Advertising/Public Relations Firms to ensure your wall is marketed to its fullest.

Conclusion

This guideline has been written to assist in the proper installation and operation of the Mobile climbing wall. Vertical Reality has tried in its best effort to address relative issues; however, there will be additional information learned or situations that occur that we are unaware of at this time. Please, do not hesitate to call seven days a week with any technical question. Remember, there may be questions, issues and/or concerns that may arise through the use of this product that are not listed or addressed in this manual, please keep us informed. It is the responsibility of the owner and/or operator of this product to contact Vertical Reality if any questions or concerns arise. As with any amusement device, physical harm can occur and operators and participants must realize that this product is a physical activity and that proper care should be taken to ensure safety. Please exercise good common sense and good judgement while operating and transporting the Mobile climbing wall.

**Mobile climbing Wall
Preventative Maintenance
Schedule**

Inspection Date:

Inspected by:

Daily

Auto-Belay Cable - Check cable for fraying, if frayed, replace cable.

Auto-Belay Cable Ends - Ensure that there are no broken strands by crimp.

Auto-Belay Cables are tracking along pulleys without restriction.

Ensure there is no cable slack in front or behind the wall.

Ensure that the oil level has at least 3 inches in the tank with all 3 or 4 routes at the top

Harness Stitching - If stitching is pulling apart, send to Vertical Reality for inspection or repair or **replace immediately**.
Air Tank Pressure - Pressure Gauge reading between 35 psi. - 40 psi. With cables at the top of wall, Hydraulic Fluid level should be minimum 3 inches from bottom with cables at the top of the wall.

Carabineer's - If the auto locking Carabiner's is not locking positively or sticking open, **replace immediately**.

Ensure the swivel turns freely. If your wall has no-twist cable (wall without swivels) refer back to cable inspections.

Ropes – make sure they are not worn out or frayed

Connection Points- check to see that they are in good condition.

Weekly

Pulley Wear - Inspect pulley's closely to ensure proper function, replace if worn.

Hydraulic Hose - Inspect for road damage and proper function. No leaks!

Tire Pressure - On mobile units, check tire for proper pressure

Cable slack - With rope; test the full length to ensure proper auto belay function.

Note: Please make copies from this page and use as directed!

Thank you and have Fun!

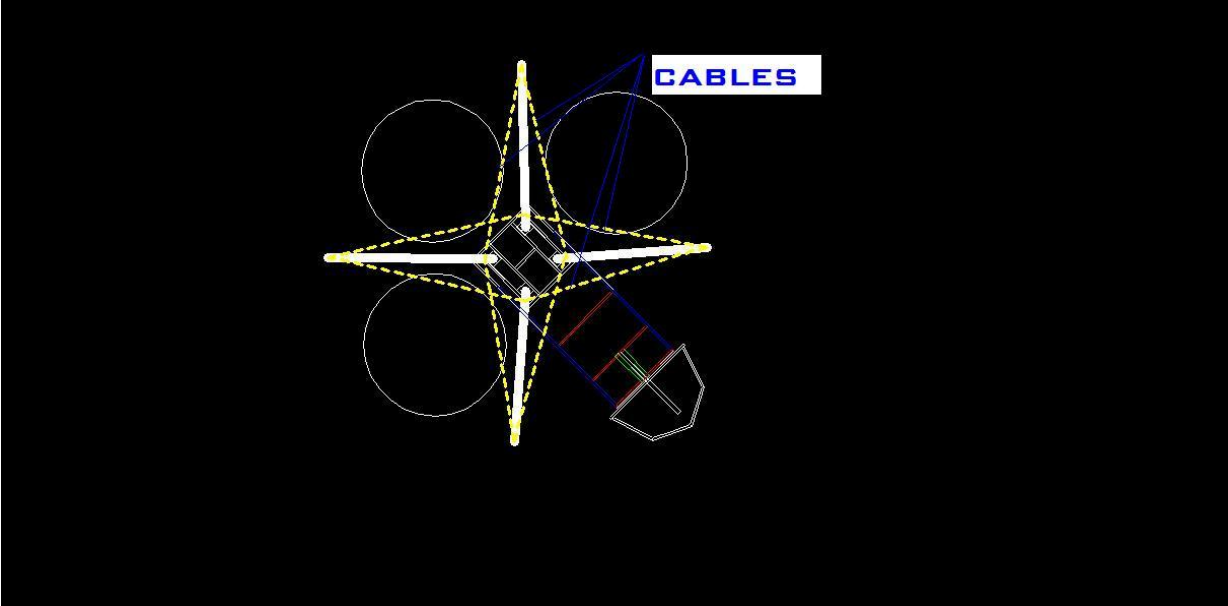



Miami, FL 33157
 Tel (305) 238-4522 Fax (305) 238-4401 Toll free (877) 632-6444
www.verticalreality.com

Thursday, July 02, 2009

ROCK WALL INSPECTION REPORT	
DATE	
VIN NO	
OWNER	
Check Cable for signs of rust total length	
Check Cable Crimps	
Date of last cable change	
Hoses tightened on all belay system	
Oil level in belay tank with cables at the top	
Pressure in belay tank with cables at the top	
Belay system checked for proper operation	
Cables retracting evenly and smoothly	
Check for rust on belay cylinders	
check welds on top pulley bracket assembly	
Harnesses in good shape no signs of loose stitching	
Carabiners working and not worn out	
Other Comments	

Inspectors Name	
Phone number	
Signature	

Accident Report Form

We anticipate that you never will have to use this form, however in the unlikely event of a accident, please fill out the following details and fax to us ASAP at 305 4432820

• Date of accident
• Place of accident
• Time of accident
• Name of injured person
• Address of injured person
• Phone of injured person
• Was 911 called and please attach a copy of the report
• Extent and nature of injury
• What caused the accident
• Was the person intoxicated or under the influence of alcohol or drugs
• Were Vertical Reality's safety rules posted
• Was your staff properly trained in the operation of the wall
• Was the wall shut down for inspection after the accident occurred
• Name of person signing the report
• Signature

Trouble Shooting Guide

Technical Problem

Trailer lighting isn't working correctly.

See appendix F to determine correct wiring

Wall won't raise.

Is the hydraulic motor getting power? **IF NO**

- Check battery voltage and connections.
- Check hand control connections.

If Yes

- Has the tie downs been removed.
- Check hydraulic fluid level.

Wall won't go down.

Is the hydraulic motor getting power? **IF NO**

- Check battery voltage and connections.
- Check hand control connections.

IF YES

- Make sure wall is raised of the ground

Auto belay cable will not retract when wall is vertical

- Check air tank pressure is between 35 and 40 psi with cables at the top
- Check for air leaks using soapy water
- Check cable routing for obstructions
- Check that pulleys are rotating freely
- Check ram alignment